

Construction Address: _____

Date: _____



Department of Building Safety

306 S North St, MI 49349 Phone 231-689-7216 or 231-224-3960 Fax 888-825-7654
Office Hours: Newaygo County Building Department, 8:00am – Noon & 1:00pm – 4:00pm
Newaygo City Hall, 28 N State Road, M-W., 1:00pm - 3:00pm (call to verify)

All sections must be answered completely. Check the appropriate box or fill in blank as required.

Size of Deck or Balcony: _____ feet (*wide*) by _____ feet (*long*)

Attached to house? Yes No **Is deck around or next to a pool?.** Yes No If yes, certain safety devices must be installed per the building code. (See back of this form)

Soil Type: Sand Clay Other (*Explain*) _____

Poles:

- A. **Type** - Pressure Treated Other (*Explain*) _____
- B. **Size** - 4" x 4" 4" x 6" 6" x 6" Other (*Explain*) _____
- C. **Spacing** - 4 feet on center 8 feet on center Other _____ feet on center
- D. **Depth of poles** - 36 inches 42 inches 48 inches Other _____ inches
- E. **Pole Support** - Foundation Blocks - Size _____ " **or** Concrete (wet) _____ " x _____ "

Deck Framing:

A. Beams

- 1. **Span:** - _____ feet between posts or supports. (See reverse side for example.)
- 2. **Size:** - 2 - 2 x 8's 2 - 2 x 10's 2 - 2 x 12's 2 - 2 x _____ 's
 Other (*Give details*) _____

B. Beam/Post Connections: Beam on post Beam let-in post Carriage/machine bolts
 Structural Screws (GRK) Other (*Explain*) _____

C. Deck Joists:

- 1. **Span:** - _____ feet between posts or supports. (See reverse side for example.)
- 2. **Size:** - 2 x 8's 2 x 10's 2 x 12's 2 x _____ 's
 Other (*Give details*) _____
- 3. **Species** - Southern Yellow Pine Ponderosa Pine Redwood
 Other (*Give details*) _____

4. **Spacing o.c.:** - 16" 24" Other _____ "

D. Decking: - 2 x 4's 2 x 6's 5/4 x 6's Other _____

Guardrails:

A. Height of deck above grade is _____ inches.

Note: If deck surface is more than 30" above the finished grade, a guardrail must be provided with a minimum height of 36" and a maximum distance between intermediate rails not to exceed 4" between them.

B. Guardrail: - Yes No If yes, answer #1. thru #3, below.

- 1. **Height of guardrail:** - 36" 40" 42" 48" Other _____ "
- 2. **Spacing between intermediates o.c.:** - 4" 5" Other _____ "
- 3. **Top rail material:** - 2 x 4's 2 x 6's 5/4 x 6's Other _____

Deck Construction Terminology:

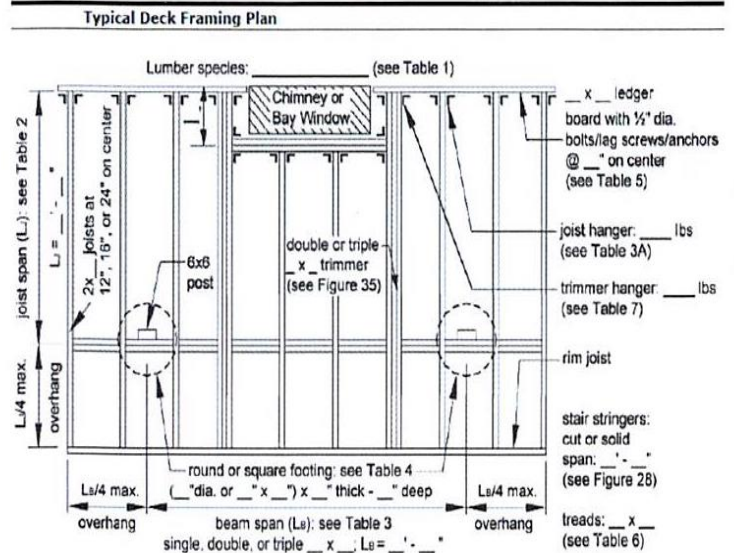
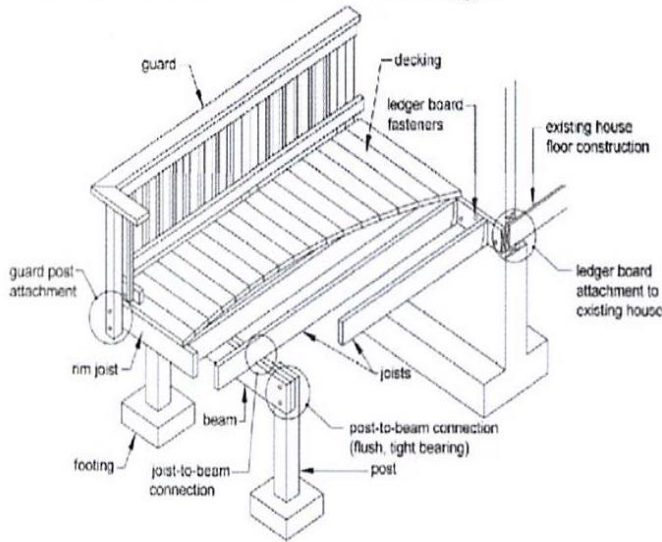

Pool Safety Devices: (If deck is located at a pool, fill out the following information.)

1) Fences/Barriers:

- a) Height of fence is _____ inches above finished ground level. (Min. of 48" with a max. opening at the bottom of barrier of 2".)
- b) Opening between verticals is _____ inches. (Max. of 4" unless solid, chain link, lattice or other climbable design. See Building Department for details on the applicable codes.)

2) Gates: Note: Pedestrian gates shall be self-closing and self-latching.

- a) Height of gate is _____ inches above ground/walk level outside the pool area.
- b) Height of self-latching device is _____ inches above the ground/walk level.
- c) The latch is located On the pool side of the gate OR Outside pool area.
 - i) (If less than 54" above the bottom of the gate, the latch shall be on the pool side a min. of 3" below the top of the gate and openings in the gate and fence shall not be greater than 1/2" within 18" of the latching devices.

3) Other:

- a) Wall Barriers with openings:
 - i) How many doors open directly into the pool area? None One or more
 - ii) Audible alarm provided? Yes No If yes, who is the manufacturer and the model number.

Pool/Deck/House Layout: (Draw a sketch of the deck, pool and house layout.)